

HANGING LAMP

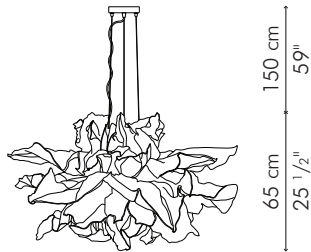

MEDIUM

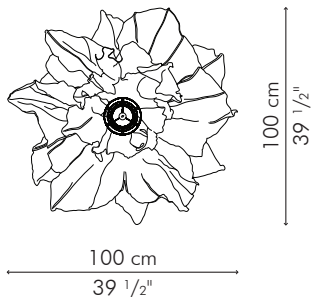

 4 kg / 9 lbs

 12 kg / 26 lbs

 0.735 m³

2 x 50 watts

code: LHFN-W-3925

SMALL

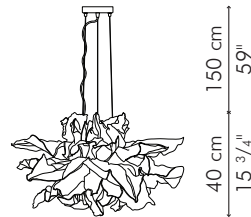
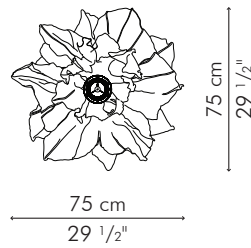

2 kg / 4 lbs

6.80 kg / 15 lbs

0.273 m³

2 x 50 watts

LHFN-W-2915

Surface mounted pre-wired lamp

G9

110V 60Hz / 230V 50Hz

INDOOR cotton fiber, aluminum, acrylic tube

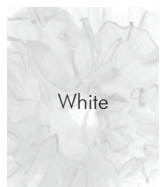

White